



BIGFOOT 3000



- AC powered
- 18 mph (29 km/h) speed
- 40 mi (64 km) range
- 3000 lb (1360 kg) load capacity*

COMFORT & PERFORMANCE UTILITY VEHICLE



An addition to the BIGFOOT line of electric “Comfort & Performance” vehicles, the Bigfoot 3000 is a utility vehicle which competes with gasoline vehicles in outdoor applications.

Equipped with a 48 volt AC motor, our GT drive and rack and pinion steering, this vehicle travels at 18 mph with a distance up to 40 miles.

Standard features include deluxe cab, aluminum drop-down sides, durable frame design, four-wheel hydraulic brakes and heavy-duty drive train that ensures reliability and low maintenance costs.

For additional vehicle images, videos, information and custom modifications visit taylor-dunn.com.

VOLTAGE	48 volt	
SPEED	up to 18 mph	up to 29 km/h
RANGE	up to 40 mi	up to 64 km
LOAD CAPACITY	up to 3,000 lb	1360 kg
TOW CAPACITY	up to 10,000 lb	4535 kg
BED SIZE (W x L)	48x74 in	122x188 cm
TURNING RADIUS	145 in	368 cm

* Based on Standard Configuration

Typical Capacity: Actual load capacity depends on application and vehicle configuration.

FEATURES & BENEFITS:

- XL Operator’s Compartment
- Tilted Steering
- Adjustable Seats



Dual USB Port



Adjustable Seats



Clear View Display



Recessed Tie-downs



Large Compartment



LED Lighting



Tilted Steering

BIGFOOT 3000



PERFORMANCE

LOAD CAPACITY	3,000 lb	1360 kg
MAX SPEED (UNLOADED)	18 mph	29 km/h
TURNING RADIUS	145 in	368 cm
TOW CAPACITY	10,000 lb	4535 kg

DIMENSIONS

OVERALL LENGTH	135 in	343 cm
OVERALL WIDTH	57 in	145 cm
HEIGHT	74 in	188 cm
WHEEL BASE	62 in	157 cm
GROUND CLEARANCE	5.8 in	14.7 cm
BED SIZE	48x74 in	122x188 cm

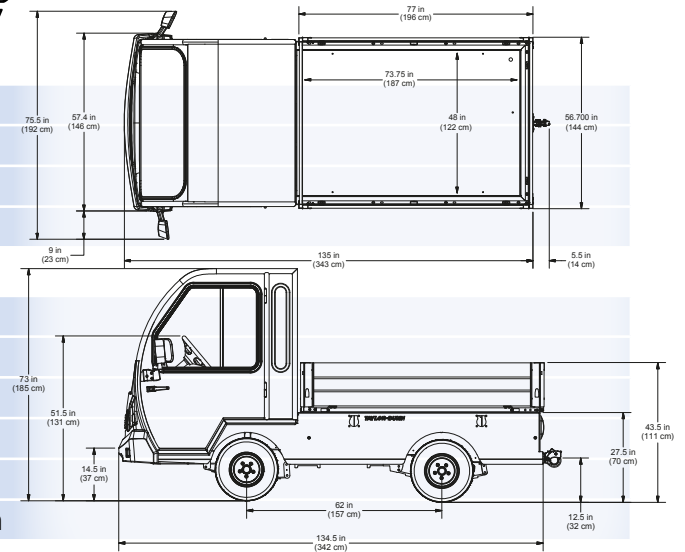

POWER SUPPLY / DRIVE TRAIN

MOTOR	17 hp, 13 kW, AC
SYSTEM VOLTAGE	48 volt
DRIVE AXLE	Helical gear, oil bath transaxle, GT automotive differential
BATTERIES	260 amp-hour, lead acid, 6 volt, 8 each
CHARGER	Built-in, 48V, 115 VAC/60 Hz, 1kW w/ interlock, High Frequency Technology
CONTROLLER	Solid-state self diagnostic AC speed controller

CHASSIS

FRAME	Fully welded, unitized, 12 gauge, smooth skin
STEERING	Rack and pinion
SUSPENSION	Multi-leaf springs, front & rear
BRAKES	Hydraulic disc brakes, front & rear, electric parking brake
BUMPERS	Heavy duty steel integrated front & rear
TIRES	20.5 x 8 x 10, load range E, pneumatic



GT Automotive Drive

GENERAL

UNIT WEIGHT	2265 lb	1027 kg
SEATS	Adjustable black bucket seats, driver's seat electrical interlock, 2 person	
INSTRUMENTATION	Clear view display (speed, distance, battery status indicator, hours, input diagnostic & fault code display), dual USB port, emergency power cut-off switch, light switch, forward/off/reverse selector, reverse buzzer, high/low speed selector, key switch, DC/DC converter (on with key switch), and floor horn switch	
LIGHT ACCESSORIES	Dual halogen headlights, LED taillights, brake lights and directional signals	
CONFORMANCE	Type E OSHA 1910.178, ANSI B56.8	

OPTIONS

- PORTABLE CHARGER
- STROBE LIGHT
- DOME LIGHT
- LADDER RACK
- HEATER
- DIAMOND PLATE DECK
- LOCKABLE CARGO BOX
- LIFT OUT BATTERY BOX
- FLAT BED DUMP
- STEEL PANEL BOX
- BATTERY WATERING SYSTEM
- VARIOUS HITCHES
- UNDERCOATING
- GALVANIZED FRAME
- OPTIONAL PAINT COLORS



CONTRACT # 051717-PSI



*Specifications, standard equipment, accessories and modifications are all subject to change without notice.

BF-030-48-1 11/17